

EXPERIENCE

VITRE LATÉRALE 80 / 100 / 120



ECO DESIGN
2 0 2 2

EXPERIENCE 80 foyer acier - vitre latérale



Puissance	12 kW
Rendement	76 %
Dimensions max. des bûches	40 cm
Dimensions	L77 cm x P65 cm x H145 cm
Efficacité énergétique saisonnière	66 %
Classe énergétique	A

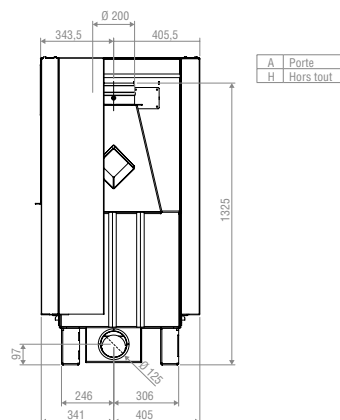
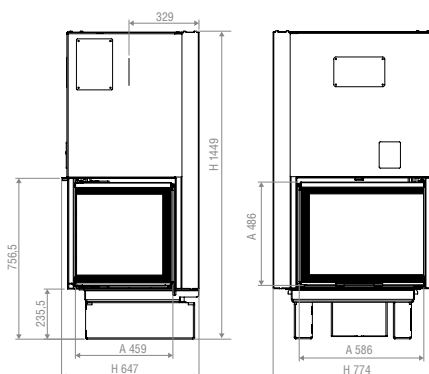

EXPERIENCE 100

foyer acier - vitre latérale



Puissance	14 kW
Rendement	75 %
Dimensions max. des bûches	50 cm
Dimensions	L97 cm x P65 cm x H145 cm
Efficacité énergétique saisonnière	65 %
Classe énergétique	A

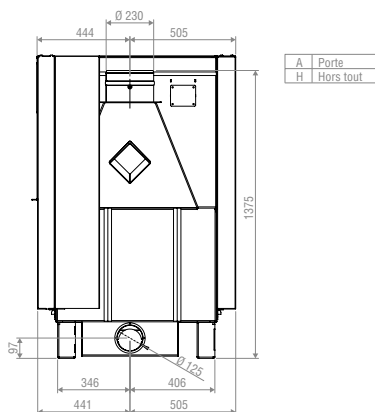
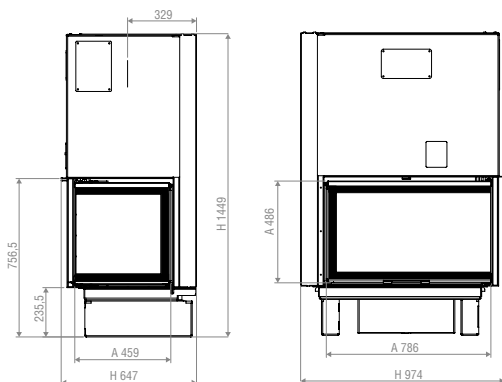

EXPERIENCE 120

foyer acier - vitre latérale



Puissance	16 kW
Rendement	75 %
Dimensions max. des bûches	50 cm
Dimensions	L117 cm x P65 cm x H145 cm
Efficacité énergétique saisonnière	65 %
Classe énergétique	A

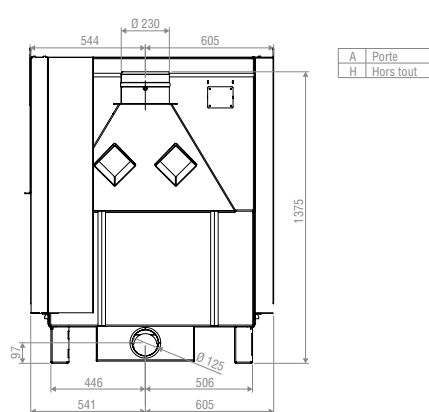
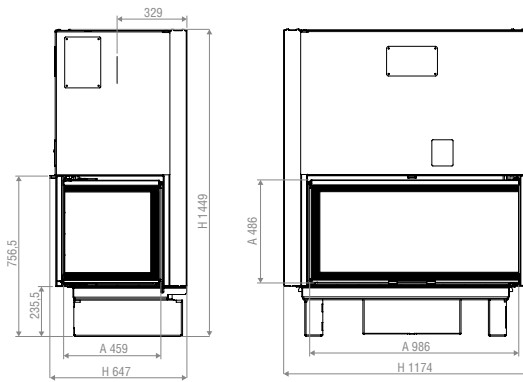

EXPERIENCE

3 VITRES 80 / 100 / 120



ECO DESIGN
2022

EXPERIENCE 80 foyer acier - 3 faces vitrées



Puissance	12 kW
Rendement	76 %
Dimensions max. des bûches	40 cm
Dimensions	L72 cm x P62 cm x H147 cm
Efficacité énergétique saisonnière	66 %
Classe énergétique	A

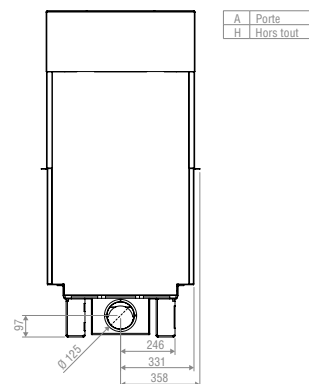
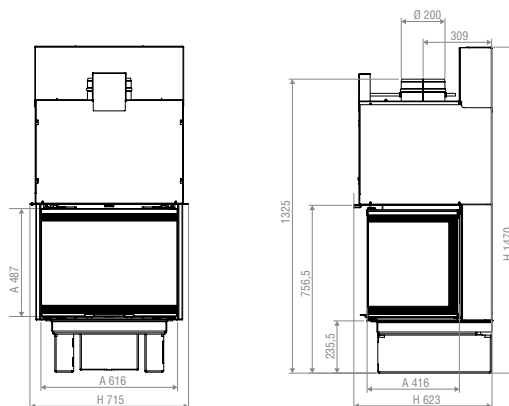

EXPERIENCE 100

foyer acier - 3 faces vitrées



Puissance	14 kW
Rendement	75 %
Dimensions max. des bûches	50 cm
Dimensions	L92 cm x P62 cm x H147 cm
Efficacité énergétique saisonnière	65 %
Classe énergétique	A

EXPERIENCE 120

foyer acier - 3 faces vitrées



Puissance	16 kW
Rendement	75 %
Dimensions max. des bûches	50 cm
Dimensions	L112 cm x P62 cm x H147 cm
Efficacité énergétique saisonnière	65 %
Classe énergétique	A

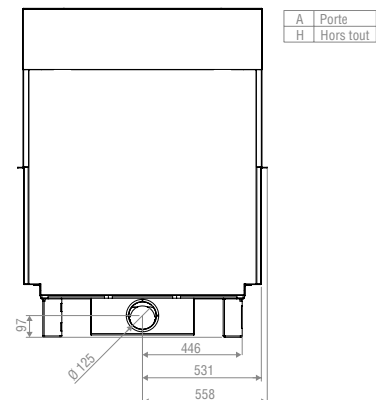
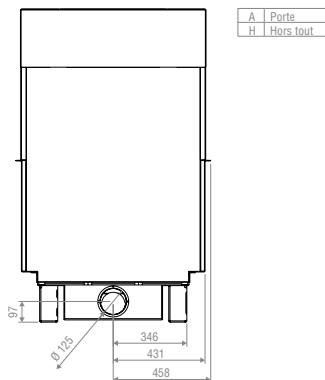
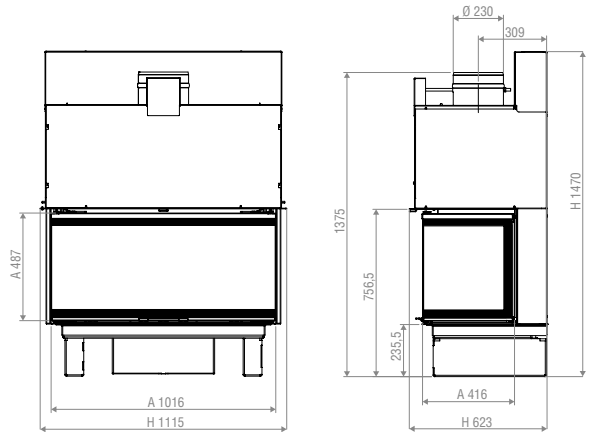
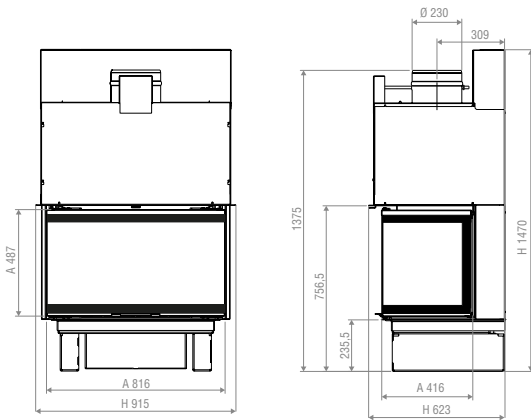

FOYERS BOIS

CARACTÉRISTIQUES TECHNIQUES



	RENDEMENT	ÉMISSION CO	ÉMISSION PARTICULES	PUISSANCE NOMINALE	OXYDE D'AZOTE (NOx) A 13% O2	COMPOSÉS ORGANIQUES VOLATILES (COV) A 13% O2	EFFICACITÉ ÉNERGÉTIQUE SAISONNIÈRE	
EXPERIENCE 80 - foyer acier - simple face	76 %	1250 mg/Nm ³	30 mg/Nm ³	12 kW	118 mg/Nm ³	86 mg/Nm ³	66 %	
EXPERIENCE 100 - foyer acier - simple face	75 %	1250 mg/Nm ³	30 mg/Nm ³	14 kW	118 mg/Nm ³	102 mg/Nm ³	65 %	
EXPERIENCE 120 - foyer acier - simple face	75 %	988 mg/Nm ³	27 mg/Nm ³	16 kW	68 mg/Nm ³	102 mg/Nm ³	65 %	
EXPERIENCE 80 - foyer acier - vitre latérale	76 %	1250 mg/Nm ³	30 mg/Nm ³	12 kW	118 mg/Nm ³	86 mg/Nm ³	66 %	
EXPERIENCE 100 - foyer acier - vitre latérale	75 %	1250 mg/Nm ³	30 mg/Nm ³	14 kW	118 mg/Nm ³	102 mg/Nm ³	65 %	
EXPERIENCE 120 - foyer acier - vitre latérale	75 %	988 mg/Nm ³	27 mg/Nm ³	16 kW	68 mg/Nm ³	102 mg/Nm ³	65 %	
EXPERIENCE 80 - foyer acier - 3 faces vitrées	76 %	1250 mg/Nm ³	30 mg/Nm ³	12 kW	118 mg/Nm ³	86 mg/Nm ³	66 %	
EXPERIENCE 100 - foyer acier - 3 faces vitrées	75 %	1250 mg/Nm ³	30 mg/Nm ³	14 kW	118 mg/Nm ³	102 mg/Nm ³	65 %	
EXPERIENCE 120 - foyer acier - 3 faces vitrées	75 %	988 mg/Nm ³	27 mg/Nm ³	16 kW	68 mg/Nm ³	102 mg/Nm ³	65 %	
EXPERIENCE 120 - foyer acier - double face	75 %	988 mg/Nm ³	27 mg/Nm ³	16 kW	68 mg/Nm ³	102 mg/Nm ³	65 %	
KW 80 - foyer acier - simple face	76,6 %	1375 mg/Nm ³	26 mg/Nm ³	9,5 kW	97 mg/Nm ³	97 mg/Nm ³	66 %	
KW 100 - foyer acier - simple face	76,6 %	1375 mg/Nm ³	35 mg/Nm ³	11 kW	101 mg/Nm ³	97 mg/Nm ³	66 %	
KW 100 - foyer acier - double face	79 %	1250 mg/Nm ³	18 mg/Nm ³	14,5 kW	59 mg/Nm ³	116 mg/Nm ³	69 %	
KW 120 - foyer acier - simple face	76,6 %	1250 mg/Nm ³	35 mg/Nm ³	12,5 kW	101 mg/Nm ³	81 mg/Nm ³	66 %	

* Se reporter aux termes de la garantie



	SORTIE DES FUMÉES	DIMENSION MAX. BÛCHES	DIMENSIONS (EN CM)	POIDS	GARANTIE*	CLASSE ÉNERGÉTIQUE	ÉTANCHE
	200 mm	40 cm	L78 cm x P62 cm x H145 cm	290 kg	10 ans	A	
	230 mm	50 cm	L98 cm x P62 cm x H145 cm	325 kg	10 ans	A	
	230 mm	50 cm	L118 cm x P62 cm x H145 cm	360 kg	10 ans	A	
	200 mm	40 cm	L77 cm x P65 cm x H145 cm	290 kg	10 ans	A	
	230 mm	50 cm	L97 cm x P65 cm x H145 cm	325 kg	10 ans	A	
	230 mm	50 cm	L117 cm x P65 cm x H145 cm	360 kg	10 ans	A	
	200 mm	40 cm	L72 cm x P62 cm x H147 cm	290 kg	10 ans	A	
	230 mm	50 cm	L92 cm x P62 cm x H147 cm	325 kg	10 ans	A	
	230 mm	50 cm	L112 cm x P62 cm x H147 cm	360 kg	10 ans	A	
	230 mm	50 cm	L118 cm x P74 cm x H145 cm	360 kg	10 ans	A	
	180 mm	50 cm	L82 cm x P50 cm x H128 cm	200 kg	10 ans	A	✓
	200 mm	70 cm	L102 cm x P50 cm x H123 cm	250 kg	10 ans	A	✓
	200 mm	70 cm	L102 cm x P64 cm x H125 cm	250 kg	10 ans	A	✓
	200 mm	90 cm	L122 cm x P50 cm x H123 cm	300 kg	10 ans	A	✓